



# Longwatch Video Engine (LVE) Installation Requirements

## Summary

The LVE is a highly-functional software application that is loaded into a user's computer to provide "at the edge" digital video recording from IP cameras, event detection and integration of video into the SCADA or HMI system. This application note is intended as a guide to help system integrators in the process of specifying the computer and related equipment for supporting the Longwatch Video Engine (LVE) software.

## Guidelines

### Hardware

**Computer** - The computer selected for the Longwatch Video Engine (LVE) should conform to the following:

Table 1 - Minimum Computer Requirements

<b>4 Camera System</b>	<b>12 Camera System</b>	<b>Multiple LVEs</b>
Pentium 4	Core 2 Duo	Core 2 Duo or higher
2 GHz, 512K L2	2 GHz, 1MB L2	2.5 GHz, 3MB L2 or higher
1GB RAM	2GB RAM	4GB RAM or higher
100Mb Ethernet	100Mb Ethernet	1GB Ethernet
Standard HDD	High Speed HDD	Raid HDD
CD-ROM Drive (Installation)		
DVD $\pm$ R/ $\pm$ RW and/or USB 2.0 (Video Transfer)		

\*Note that if using Networked Attached Storage (NAS), Gigabit Ethernet is recommended

**Cameras** - The LVE works with any of the Longwatch natively supported IP cameras as well as any camera created with the Longwatch camera toolkit. Any analog camera can also be used with the LVE with the addition of a supported analog to IP video encoder.

**Storage** - The following table should be used to determine the amount of storage needed for the LVE. This storage can be internal or shared hard drives, external USB/Firewire drives, NAS drives, or Storage Area Networks.

Table 2 - Storage Capacity Guidelines

<b>Days@Resolution</b>	<b>4 Cameras</b>	<b>12 Cameras</b>	<b>24 Cameras</b>
5 days@640x480	100 GB	300 GB	600 GB
5 days@1280x1024	400 GB	1.2 TB	2.4 TB
10 days@640x480	200 GB	600 GB	1.2 TB
10 days@1280x1024	800 GB	2.4 TB	4.8 TB
30 days@640x480	600 GB	1.8 TB	3.6 TB
30 days@1280x1024	2.4 TB	7.2 TB	14.4 TB

**Arm/Disarm** – A means should be provided to arm and disarm the system. This can be done locally through the Longwatch VCC Administrator user interface, through an HMI or other 3rd party applications, or remotely through hardware such as Digital I/O, Access Control keypads, or card readers.

**Access Control** – The LVE fully supports Access Control through the following equipment: In addition to being used for arming and disarming, Keypads can be used as an interface for Access Control to control door strikes.

*Card Readers* are available from ISONAS and HID. All ISONAS IP readers, which connected via Ethernet and TCP/IP, are supported. The HID ProxPro®, ProxPro® with Keypad, and MaxiProx® products, which connect via RS232 or RS485 serial connections, are also supported.

*Door Strikes, Switches, & Remote Exit (REX) Devices* are respectively used to unlock doors, determine if a door is open, and to allow a door to be opened without triggering an alarm. These devices are all required for most access control applications and must be accessible to the LVE. When the LVE is used with ISONAS readers, it is connected directly to the card reader, which it then interrogates and controls. For HID readers, these devices must be connected to the LVE through Ethernet I/O.

**Event Detection** – There are several methods available to the LVE for the detection of events, which are used for alarming and for triggering Longwatch video event clips.

Software based methods include automatic *Video Motion Detection*, where the LVE “watches” the video stream and triggers an event based on the motion that it detects. SCADA/HMI systems can be configured to automatically trigger events using either *OPC* or *Modbus/TCP*. Events can also be manually triggered through the *VCC Administrator* or *LVE Administrator* user interfaces.

Hardware based event detection methods include using the Alarm Inputs that are built into the *IP Cameras* or to use the discrete input channels on *Ethernet I/O servers*. Both of these methods require external initiating devices such as door switches, motion detectors, smart fences, pressure or temperature switches, moisture detectors, or any devices that provides a contact closure type signal.

**Serial Connectivity** – Keypads and HID card readers require RS232/485 serial connectivity. Additionally, the LVE can be configured to connect to the Longwatch VCC using serial protocols such as PLC protocols or Longwatch's SIO protocol. Currently each serial device must be connected using a dedicated serial port. Longwatch supports both internal serial ports and Ethernet serial port servers.

**Ethernet I/O** – A number of the LVE capabilities are best implemented using hardwired devices. These include:

- Initiating devices for event triggers.
- Initiating devices for PTZ preset position control.
- Alarming devices such as horns, beacons and strobes.
- Lighting control through lighting contactors.
- Operational devices such as valves, solenoids, or annunciators.
- Status indicators and warning beepers in conjunction with serial keypads.
- As a part of access control solutions for monitoring of door switches and REX devices as well as for door strike control.

Ethernet I/O devices are accessed by the LVE over a TCP/IP connection. These devices communicate using the Modbus/TCP protocol and are available from several vendors. The ADAM-6050 is an example of such a device.

**Reliability & Ruggedization** – There are a number of options to consider that will each contribute to a longer lasting and more dependable system. Additionally, hardened systems also provide for better scalability and result in minimal support and maintenance requirements. Such options include:

- Redundant power supplies and NIC's
- UPS or battery backup power
- RAID drives
- High quality, environmentally rated cables and connectors
- Grounding and lightning/surge protection
- Site appropriate shock, vibration and temperature specifications
- Environmental protection against water, dust, salt spray, and corrosive environments

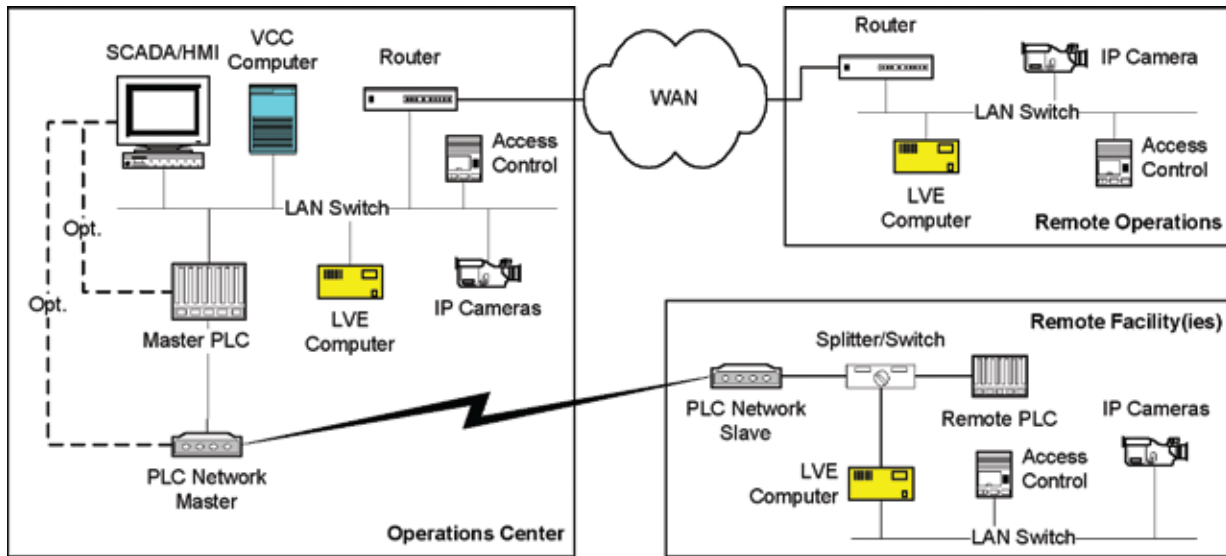

Figure 1 - **Possible LVE Locations** (Serial Connectivity and Event Detection not Shown)

## Software

**Operating System** - The LVE should be installed on a computer running one of the following operating systems:

- Microsoft Windows XP Professional, SP2
- Microsoft Windows Server 2003, SP2

To use Longwatch security and encryption provisions, the operating system drive should be formatted as an NTFS file system.

TCP/IP support must be enabled and Windows Firewall should be turned off unless it is configured to allow Longwatch programs and services to be accessed by a remote computer.

The following applications must be installed prior to the installation of the LVE:

- Microsoft Internet Explorer 7.0, or later
- Microsoft DirectX 9.0c, or later
- Microsoft Media Player 9, or later

Adobe Acrobat Reader 5.0, or later, is required to display the Longwatch documentation.

**Time Synchronization** – The LVE should be time synchronized with the Longwatch VCC. For Serially connected LVE's, this will be done automatically by the VCC. In this case the LVE computer should be configured to not automatically synchronize its clock. For LAN or WAN connected LVE's, the clocks should be configured to synchronize to the VCC computer, which should both be configured as a time server. In both cases, the VCC should always be configured to regularly synchronize with a reliable time source.

**Credentials** – The LVE can be run as both a service or foreground application. A user must be logged into the computer in order for the LVE to be run in the foreground. The LVE by default is installed as a service with the preconfigured LogOn user, LongWatchService. If a change is made to the default LogOn user, you must make sure that the user has the “Password never expires” checkbox checked. It is also important to make sure the user selected has the proper permissions to access the network.

**Remote Control** – It is recommended that the LVE computer be run “headless”, that is without a keyboard, mouse, and monitor. In cases where it is necessary to access the local computer running the LVE, a keyboard, mouse, and monitor can be added or the desktop can be accessed using remote control software such as pcAnywhere or RealVNC. The use of remote control software is also useful when the LVE is located at a remote location, but is accessible via TCP/IP.

## **Networking and Communications**

There are two methods of connecting the LVE to a VCC, over TCP/IP networks (LAN/WAN) or over serial connections.

Serial methods include using PLC protocols such as Modbus, Allen-Bradley's DF1, Bristol's BSAP, and others. Also dedicated serial networks are supported using Longwatch's SIO protocol or through Dial-Up analog modems.

Connectivity over TCP/IP networks can be setup using any network topology, including LAN, WAN, Satellite, DSL, Cable Modem, Fiber, Radio, Cellular, T1, Leased Lines, or any other network that is configured for TCP/IP. The only requirement is that the LVE should be configured using a static IP address and the routing between the VCC and LVE must allow two-way communications using specific ports associated with Longwatch VCC to LVE communications.

**Security** – IPSec is fully supported in the LVE and is recommended for all computer to computer communications. LVE to VCC communications alternatively may be encrypted using a Longwatch implementation of Rijndael/AES 128 bit encryption, which can be turned on during configuration.

Microsoft Windows Username/Password security can be incorporated into the Longwatch VCC Administrator and LVE Administrator user interfaces to control access to the configuration screens.

The LVE and most IP cameras can also be configured to perform IP Address filtering. Additionally, most IP cameras allow for IEEE 802.1x network admission control to further protect equipment at the port level.

Wireless networks should be protected using WPA pass code protection.

For additional security, installations should conform to IT best practices and network engineering.

**High Camera Counts** – The LVE transports all video signals using the network. For installations where there is a significant camera count, certain additional steps should be pursued. The determination of what is significant is a function of the current use of the network as well as the network topology. The following will provide for more efficient network utilization, where required:

- Upgrade to Gigabit Ethernet (Required for multiple LVE installations)
- Dedicated Network Interface Card (NIC) for the LVE to connect to Cameras.
- Implementation of network management protocols such as QoS, IGMP Snooping, and ECN, on Layer 3 Managed Network Backbone Switch and Layer 2 edge switches
- Virtual LAN configuration (Segmentation) or dedicated physical network. If wireless networks are used, isolate frequencies used for video.

### ***Related Resources***

Longwatch HMI Integration Manual

Longwatch TechNote, “Serial Connectivity for the LVE”

Longwatch LVE User’s Guide

Longwatch TechNote, “Ethernet I/O for the LVE”

Longwatch AppNote, “Camera Selection”